



Multiple Choice Questions

Examination Rules

1. You have to sit at your designated desk.
2. Before the examination starts, you must check the stationery and any tools (pen, ruler, calculator) provided by the organizers.
3. You are not allowed to bring any tools except personal medicine or approved personal medical equipment.
4. You have to check the question and answer sheets provided. Raise your hand, if you find any missing sheets. Start tasks after the start whistle is blown.
5. During the examination, you are not allowed to leave the examination room except in an emergency and then you will be accompanied by a supervisor/volunteer/invigilator.
6. You are not to disturb other competitors. If you need any assistance you may raise your hand and wait for a supervisor to come to assist.
7. There will be no discussion about the examination tasks or problems. You must stay at your desk until the examination is over, even if you have finished the examination.
8. At the end of the examination time you will hear a whistle blow. You are not to write anything on the answer sheet after this stop whistle. You must leave the room quietly when asked to do so. The question and answer sheets must be left neatly on your desk.

Multiple Choice Questions

READ THE FOLLOWING INSTRUCTIONS CAREFULLY

- A. The time available is 3 hours.
- B. Check that you have a complete set of the test questions and the answer sheet. The total number of questions is 30.
- C. Write down your name, code, country and signature in your answer sheet.
- D. Read carefully each problem and choose your correct answer by crossing one of the capital letters in your answer sheet. There is only one right answer for each problem.

Example:

1	A	B	C	D
---	--------------	---	---	---

- E. If you want to change your answer, you have to circle the first answer and then cross a new letter as your correct answer. You are only allowed to make one correction per question.

Example:

1	⊗ A	B	C	B
---	--------	---	---	--------------

D is the final answer

- F. Grading rules:

- (i) Correct answer : + 1 point
- (ii) Wrong answer : - 0.25 point
- (iii) No answer : 0 point

Multiple Choice Questions

Time : 3 hrs
Marks : 30

1. Which among the following numbers is the largest?
- (A) The number of air molecules in a $3\text{ m} \times 3\text{ m} \times 3\text{ m}$ classroom.
 - (B) The number of water molecules in a one-litre bottle filled with water.
 - (C) The number of breaths you have taken since your birth.
 - (D) The number of seconds which have passed since the origin of the Universe.
2. The Moon was observed near the eastern horizon at the Equator just before sunrise. The shape of the Moon would have been closest to:



Multiple Choice Questions

3. An opaque hemisphere of radius R lies on a horizontal plane as shown in the figure below.

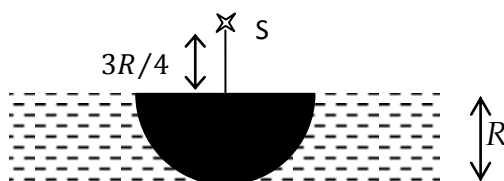

On the perpendicular through the point of contact, a point source of light S is placed at a distance $3R/4$ above the centre of the hemisphere. A transparent liquid of refractive index $4/3$ is filled above the plane such that the hemisphere is just covered with the liquid. The area of the shadow on the horizontal plane is

- (A) $49\pi R^2/9$ (B) $49\pi R^2/16$ (C) πR^2 (D) $4\pi R^2$
4. Two conducting circular loops F and G are kept in a plane on either side of a straight current-carrying wire as shown in the figure below.

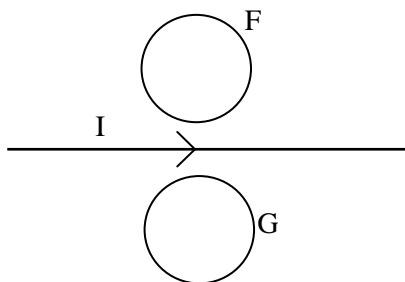

If the current in the wire decreases in magnitude, the induced current in the loops will be

- (A) clockwise in F and clockwise in G .
 (B) anti-clockwise in F and clockwise in G .
 (C) clockwise in F and anti-clockwise in G .
 (D) anti-clockwise in F and anti-clockwise in G .

Multiple Choice Questions

5. The equation of state for one mole of a *real* gas is given, in terms of pressure p , volume V and absolute temperature T , by van der Waals' equation

$$\left(p + \frac{a}{V^2}\right)(V - b) = RT$$

where a has the value α in $\text{kg m}^5 \text{s}^{-2} \text{mol}^{-2}$, b has the value β in $\text{m}^3 \text{mol}^{-1}$, and $R = 8.31 \text{ J K}^{-1} \text{mol}^{-1}$ is the universal gas constant. If the gas is kept in a container with rigid walls of volume 1 m^3 , the minimum temperature (in K) that the gas can be cooled to is

- (A) $\alpha(1 - \beta) / 8.31$ (B) $(1 - \beta) / 8.31$ (C) $\alpha / 8.31$ (D) zero
6. The nuclei of a radioactive element decay to nuclei of another element at a rate proportional to the number of nuclei of the first element. Consider that a radioactive element X decays to another radioactive element Y, which further decays to a stable (non-radioactive) element Z. If you start with a sample containing only the element X, a plot of the number of nuclei of Y, $N(Y)$, as a function of time, t , can look, on a long time scale, like

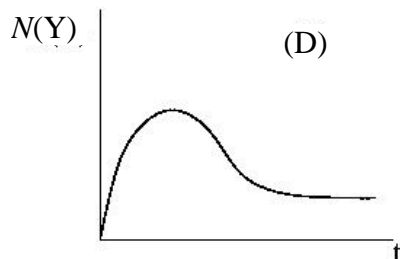
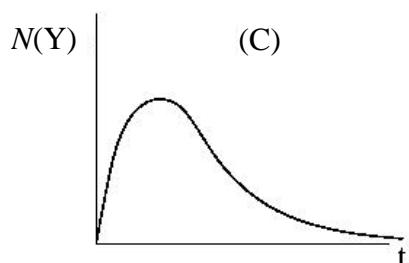
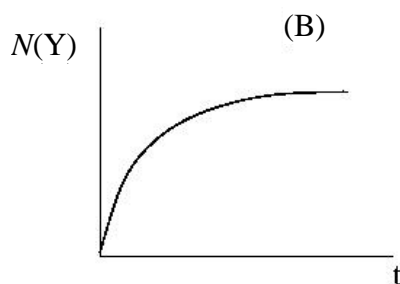
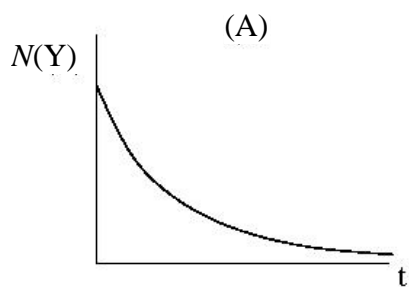

Multiple Choice Questions

7. Consider six resistances connected as shown in the figure below. Note that the extreme ends are shorted. A circuit element consisting of a 6 V ideal battery and an ideal ammeter can be connected across any two of the different points marked by dots in the resistance network.

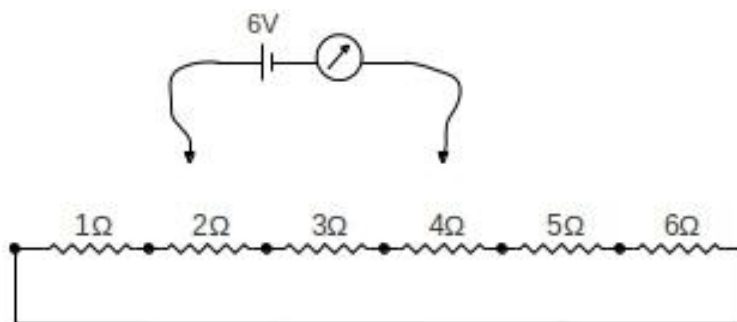

The *minimum* possible value of the current passing through the ammeter would be

- (A) 0.29 A
(B) 1.15 A
(C) 1.17 A
(D) 1.41 A
8. Playing with a lens one morning, Rita discovers that if she holds the lens 0.120 m away from a wall opposite to a window, she can see a sharp but upside-down picture of the outside world on the wall. That evening, she covers a lighted lamp with a piece of card on which she has pierced a small hole, 0.005 m in diameter. By placing the lens between the illuminated card and the wall, she manages to produce a sharp image of diameter 0.020 m on the wall. What is the distance between the card and the wall?
- (A) 0.450 m
(B) 0.750 m
(C) 0.600 m
(D) 0.300 m

Multiple Choice Questions

9. Equal amounts of ice at 0°C are placed in three containers P, Q and R, which are kept in a constant temperature environment. Identical heating elements are placed inside each container. These heating elements are powered with different voltages: 100 V, 200 V and 300 V in containers P, Q and R, respectively. It was found that it took 20 minutes to melt all the ice in container Q, and it took 4 minutes to melt all the ice in container R. Assuming that at any instant heat is uniformly dissipated in each container throughout its volume, which of the following is correct?
- (A) It will take (approximately) 80 min to melt all the ice in container P.
 (B) It will take (approximately) 100 min to melt all the ice in container P.
 (C) It will take (approximately) 132 min to melt all the ice in container P.
 (D) It will not be possible to melt all the ice in container P with the given power source.
10. The figure below shows a glass flask whose hemispherical base is of diameter 0.20 m. The height of the flask is 0.25 m. The flask is filled to the brim with 2.5 litres ($1\text{ litre} = 10^{-3}\text{ m}^3$) of water and sealed with a glass lid.

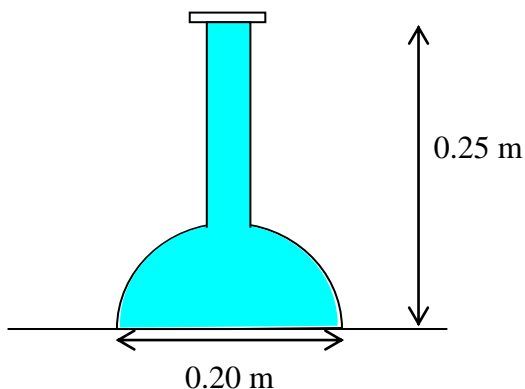

What is the approximate magnitude of the total vertical force exerted by the water on the curved surface of the flask? (Take the acceleration due to gravity, g , to be 10 ms^{-2}).

- (A) 0 N (B) 78.5 N (C) 53.5 N (D) 25.0 N

Multiple Choice Questions

11. Consider an element with 7 electrons. In the ground state, these electrons may be arranged in 1s, 2s and 2p orbitals in four different ways.

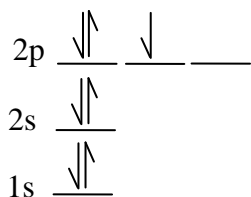

Fig 1

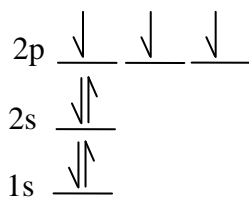

Fig 2

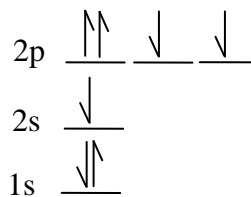

Fig 3

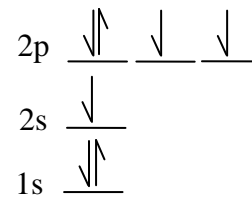
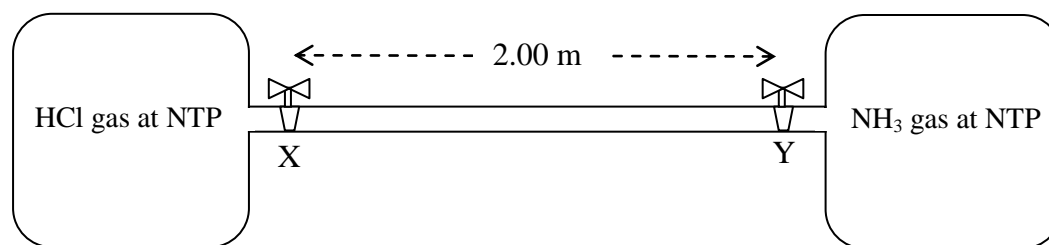

Fig 4

Choose the CORRECT statement from the following.

- A. Fig 4 and Fig 2 are correct..
B. Only Fig 2 is correct.
C. Only Fig 1 is correct.
D. Fig 3 and Fig 4 are correct.
12. A glass pipe is connected on either side to gas reservoirs, one containing HCl gas at normal temperature and pressure (NTP) and the other containing NH₃ gas, also at NTP. X and Y are two stop-cocks, separated by 2.00 m, which, when closed, prevent the flow of gas into the glass pipe.



It was observed that when the stop-cocks X and Y were opened simultaneously, then white fumes first appeared at a point P inside the glass pipe between X and Y. The distance of the point P from the stop-cock X is nearly

- (A) 1.00 m (B) 1.19 m (C) 0.81 m (D) 0.62 m

Multiple Choice Questions

13. The physical adsorption of x grams of neon gas on m grams of activated charcoal adsorbent at pressure p is correctly represented by

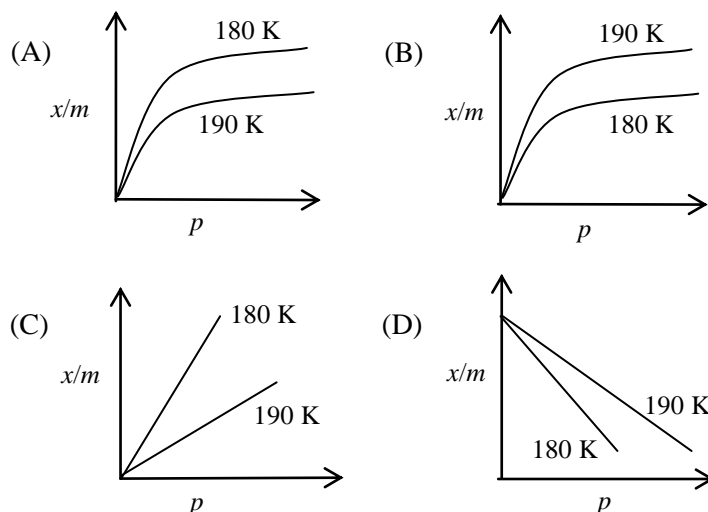

14. In a conductometric titration experiment, a solution of 0.1 M $\text{Ba}(\text{OH})_2$ is titrated against a solution of 0.1 M MgSO_4 , and the conductance of the mixture is continuously measured. The correct variation of conductance of the reaction mixture with the titration volume of MgSO_4 is best represented by

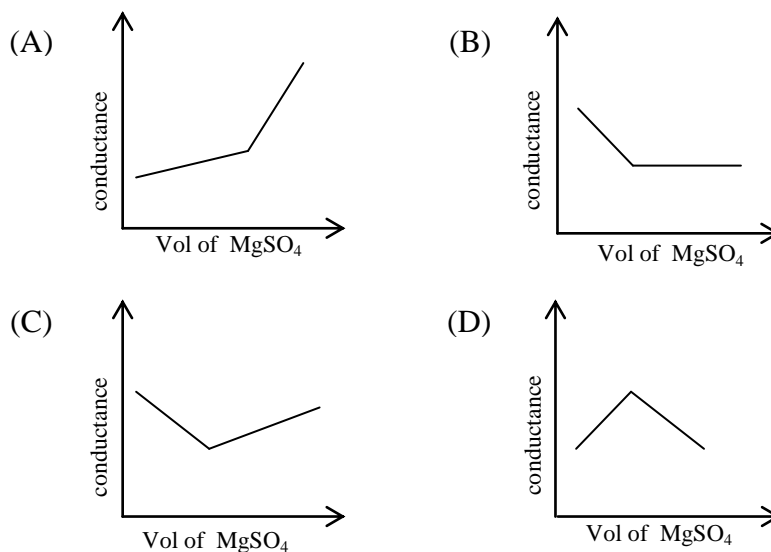

Multiple Choice Questions

15. The phase diagram (pressure against temperature) for a substance S is given below.

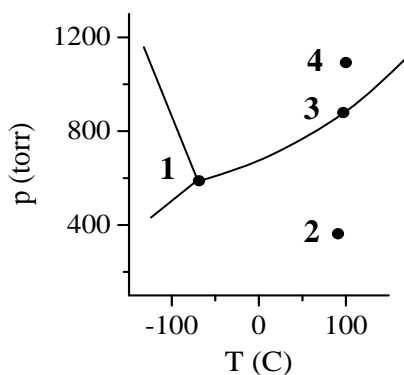

Consider the following statements for the substance S:

- (i) at point **1**, solid S can spontaneously convert to gaseous S but not to liquid S.
- (ii) at point **2**, liquid S can be in equilibrium with gaseous S.
- (iii) at point **3**, liquid S can start boiling to gaseous S.
- (iv) at point **4**, S is in liquid state.

Which of the following is correct for the substance S?

- (A) Statements (ii) and (iv) are correct.
- (B) Statements (i) and (ii) are correct.
- (C) Statements (i) and (iii) are correct.
- (D) Statements (iii) and (iv) are correct.

16. In the pharmaceutical industry, a chemical analysis of aspirin involves the following reaction

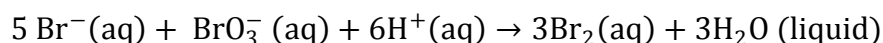

In one such analysis it was found that the rate of formation of Br_2 at a particular instant was 0.25 mol s^{-1} . This indicates that the rate of disappearance of Br^{-} (in mol s^{-1}) would be

- (A) 0.50
- (B) 0.42
- (C) 0.15
- (D) 0.83

Multiple Choice Questions

17. Corrosion of iron pipes occurs in the presence of water. To prevent such corrosion, iron pipes are normally coated with an element like magnesium using electroplating.

Which of the following statements is correct?

- (A) During corrosion of an un-plated iron pipe, water is oxidized; during electroplating, iron acts as anode.
- (B) During corrosion of an un-plated iron pipe, oxygen is reduced; during electroplating, iron acts as cathode.
- (C) During corrosion of an un-plated iron pipe, iron is oxidised; during electroplating, magnesium is deposited on the anode.
- (D) During corrosion of an un-plated iron pipe, iron is reduced; during electroplating, magnesium is deposited on the cathode.

18. HCl (acid) and NaOH (base) dissociate in water (H₂O) as:



and neutralize by the reaction $\text{H}^+ + \text{OH}^- \rightarrow \text{H}_2\text{O}$.

Now consider the following statements about the analogous reaction of NH₄Cl and KNH₂ in liquid NH₃ as solvent.

- (i) NH₄Cl acts as an acid and KNH₂ acts as a base.
- (ii) NH₄Cl acts as a base and KNH₂ acts as an acid.
- (iii) The reaction of NH₄⁺ and NH₂⁻ is a neutralization reaction.
- (iv) The reaction of K⁺ and Cl⁻ is a neutralization reaction.

Which of the following statements is correct?

- (A) (i) and (iii)
- (B) (ii) and (iii)
- (C) (i) and (iv)
- (D) (ii) and (iv)

Multiple Choice Questions

19. The solubility product of PbBr_2 is $K_{sp} = 6.3 \times 10^{-6}$ at room temperature. If 50 ml of 0.02 M $\text{Pb}(\text{NO}_3)_2$ are mixed with 50 ml of 0.01 M CaBr_2 , then
- (A) PbBr_2 will precipitate and excess Br^- will remain in solution.
 (B) $\text{Ca}(\text{NO}_3)_2$ will precipitate.
 (C) PbBr_2 will precipitate and excess Pb^{2+} will remain in solution.
 (D) no precipitate will form.
20. Consider the three molecules NH_3 , PH_3 and AsH_3 . Which of the statements below is INCORRECT?
- (A) Each of the 3 molecules has a pair of unshared valence electrons.
 (B) Each of the molecules is polar.
 (C) Each of the molecules contains three sigma bonds.
 (D) Each of the molecules is planar and triangular.
21. Nucleic acids can be double stranded (ds) or single stranded (ss). The following table gives the composition of bases in four different nucleic acid samples.

	Amount of base (%)				
	A	T	G	C	U
Sample 1	40	40	10	10	0
Sample 2	10	40	40	10	0
Sample 3	40	0	40	10	10
Sample 4	40	0	20	10	30

Using the information given above, it may be deduced that the samples 1, 2, 3, 4 are

- (A) 1 : dsDNA, 2 : ssDNA, 3 : ssRNA, 4 : ssRNA.
 (B) 1 : dsDNA, 2 : ssRNA, 3 : dsDNA, 4 : ssDNA.
 (C) 1 : ssDNA, 2 : dsDNA, 3 : ssRNA, 4 : dsRNA.
 (D) 1 : dsDNA, 2 : ssRNA, 3 : ssDNA, 4 : ssDNA.

Multiple Choice Questions

22. The following is the pedigree of a family from a marriage between first cousins. Males are represented by squares and females by circles. The family has a very rare X-linked trait. Out of their progeny (individuals 1, 2, 3 in the figure), individual 3, who expressed this trait, married outside the family to individual 4, who is not a carrier of this trait.

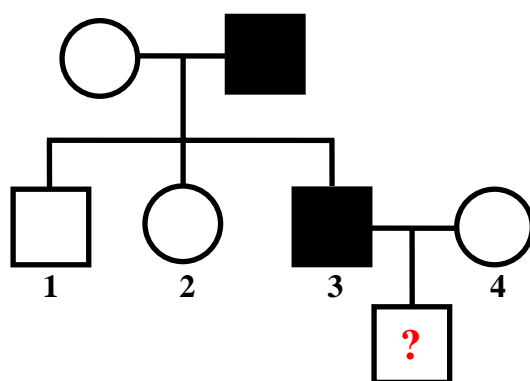

Consider the following statements regarding the above trait:

- (i) The trait is recessive.
- (ii) The trait is dominant.
- (iii) The probability that the daughter (individual 2) is a carrier is 0.
- (iv) The probability that the daughter (individual 2) is a carrier is 1.
- (v) The probability that a son born to individuals 3 and 4 will express the trait is 0.
- (vi) The probability that a son born to individuals 3 and 4 will express the trait is 0.5.

Which of the above statements are correct?

- (A) (i), (iii) and (vi)
- (B) (i), (iv) and (v)
- (C) (ii), (iii) and (vi)
- (D) (ii), (iv) and (v)

Multiple Choice Questions

23. The following flow chart represents the feedback loops that regulate secretion of thyroid hormones (T3 and T4). Such secretion essentially regulates the basic metabolism rate in mammals. The '+' and '-' signs represent positive and negative regulation, respectively.

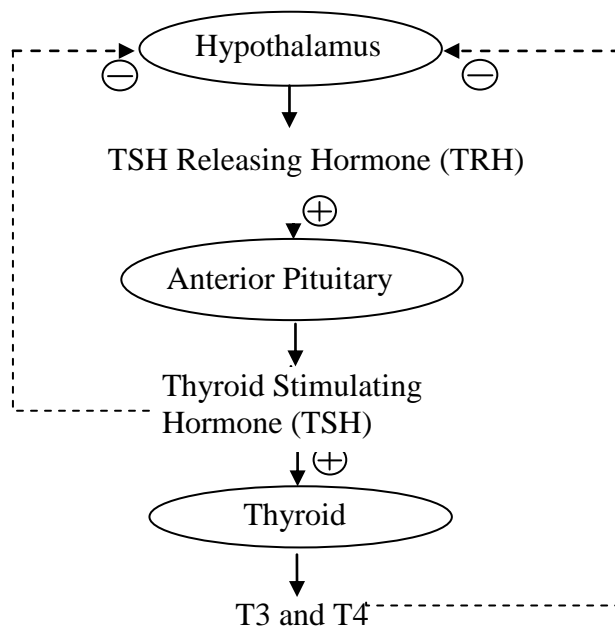

Three disease conditions are being studied where (x) the anterior pituitary fails to produce TSH, (y) the thyroid fails to produce T3 and T4 and (z) the hypothalamus fails to secrete TRH. In the Table below, match the hormone levels in column A with the disease conditions in column B.

Column A		Column B	
(i)	Low TRH, Low TSH and Low T3, T4	(x)	Anterior pituitary fails to produce TSH
(ii)	High TRH, High TSH and Low T3, T4	(y)	Thyroid fails to produce T3 and T4
(iii)	High TRH, Low TSH and Low T3, T4	(z)	Hypothalamus fails to secrete TRH

Which of the following is the correct match for the above?

- (A) (i) – (x) ; (ii) – (y) ; (iii) – (z)
- (B) (i) – (z) ; (ii) – (y) ; (iii) – (x)
- (C) (i) – (y) ; (ii) – (x) ; (iii) – (z)
- (D) (i) – (z) ; (ii) – (x) ; (iii) – (y)

Multiple Choice Questions

24. DNA replicates in a semi-conservative manner in which each individual strand is copied to form a new molecule of DNA. The two strands can be labelled with isotopes using substrates that contain either normal ^{14}N or its heavy isotope ^{15}N . In an experiment, one strand of DNA was labelled with ^{14}N and the other with ^{15}N (hybrid DNA). The hybrid DNA was then allowed to replicate in the presence of the ^{14}N -labelled substrate. If one started with a single molecule of hybrid DNA and allowed it to replicate over 4 cycles, what would be the proportion of double-stranded DNA molecules labelled with ^{15}N ?

- (A) 1/4
- (B) 1/8
- (C) 1/16
- (D) 1/32

25. Assimilation of CO_2 by photosynthesis in cacti growing in arid regions occurs in two stages. In stage 1, CO_2 uptake and fixation occurs at night and CO_2 is stored in the form of malate in vacuoles. In stage 2, during the day the malate moves to the chloroplast where it is decarboxylated, and the released CO_2 is re-fixed by RuBP carboxylase. The main reason for this is:

- (A) Cacti require light for RuBP carboxylase activity.
- (B) Cacti close their stomata during the day, so availability of CO_2 for RuBP carboxylase activity is low during the day.
- (C) Cacti can fix CO_2 only at an acidic pH that is provided by malate.
- (D) Cacti have chloroplasts that are impermeable to CO_2 but are permeable to malate.

Multiple Choice Questions

26. Charles Darwin observed that seedlings grow towards light. He called this response 'phototropism.' In an experiment two light sources are used to illuminate each seedling. Each source is indicated by a yellow circle in the diagrams below. The larger yellow circle represents a light source with twice the illumination than the light source represented by the smaller yellow circle.

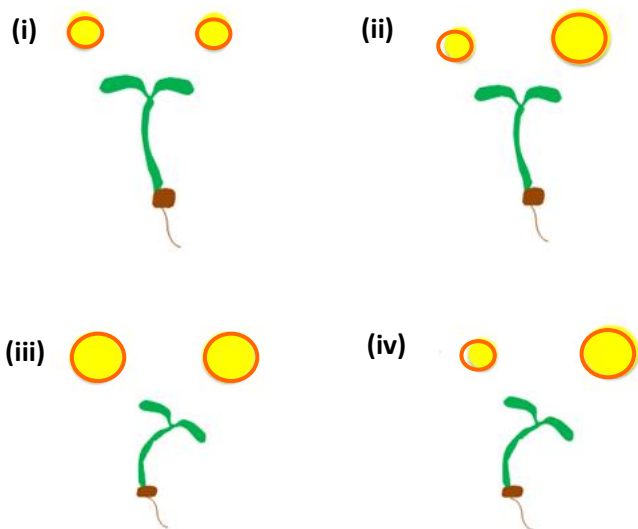

Which of the above responses would be observed?

- (A) only (iv)
 - (B) only (ii)
 - (C) (i) and (iii)
 - (D) (i) and (iv)
27. In an eukaryotic cell, mitochondria and chloroplasts are thought to have originated through endosymbiosis, a process in which an organism engulfs another and the two continue to exist in a mutually beneficial arrangement. Which of the following observations best supports this theory?
- (A) These organelles exchange metabolites with other cellular compartments.
 - (B) These organelles are capable of independent existence outside the cell.
 - (C) These organelles have their own genetic material.
 - (D) These organelles provide energy in the form of ATP to the cell.

Multiple Choice Questions

28. The Human Immunodeficiency Virus (HIV) can cause the disease AIDS. The HIV infects lymphocytes, the T-cells, that help in the production of antibodies. The following graph shows how the concentrations of HIV, T-cells, and antibodies against HIV develop in time in an untreated AIDS patient.

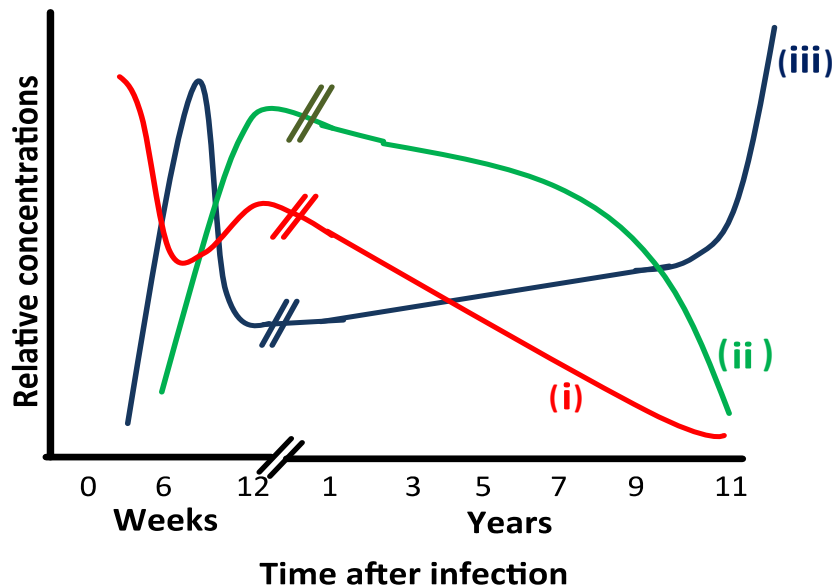

In the above graph, the lines marked (i), (ii) and (iii), respectively, represent

- (A) HIV, T-cells and antibodies.
- (B) T-cells, HIV and antibodies.
- (C) T-cells, antibodies and HIV.
- (D) Antibodies, T-cells and HIV.

Multiple Choice Questions

29. Consider a hypothetical population, where all members have access to abundant food and they are free to reproduce at their physiological capacity. Which one of the following curves best represents the population growth expected under such conditions?

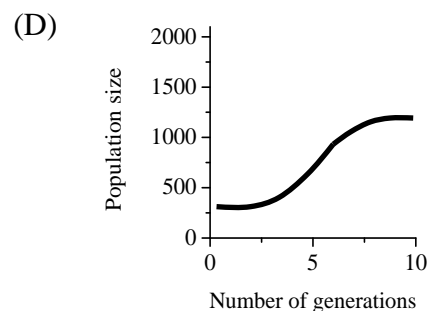
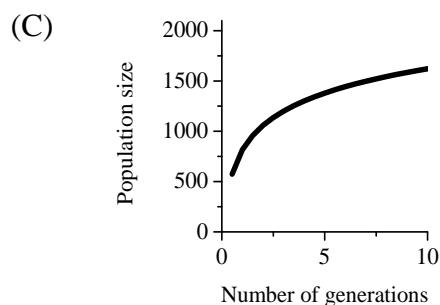
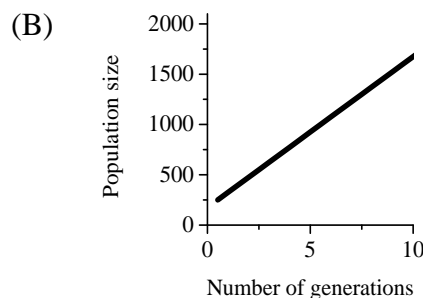
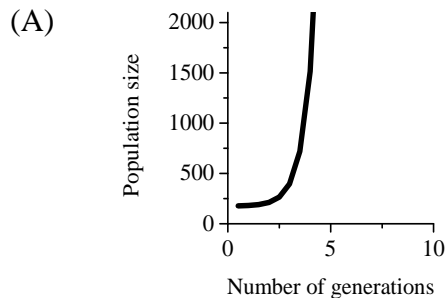

30. Ammonia, urea and uric acids are toxic, nitrogenous waste products produced by break down of protein and nucleic acids. These waste products have to be excreted. Ammonia is highly toxic and has a high solubility in water. Urea is less soluble and less toxic than ammonia. Uric acid is least toxic and has low solubility. Excretion of nitrogenous waste from a frog and a tadpole would primarily be as

- (A) Urea in tadpole and ammonia in frog.
- (B) Ammonia in tadpole and urea in frog.
- (C) Urea in both tadpole and frog.
- (D) Uric acid in tadpole and urea in frog.